

FEIDER

MACHINES



PETROL HEDGE TRIMMER

Model: FHT22

USER GUIDE

CAUTION: Read the instructions before using the machine!

CONTENTS

1. SAFETY INSTRUCTIONS	3
2. YOUR PRODUCT	6
3. FILLING WITH FUEL	7
4. OPERATION	8
5. MAINTENANCE AND STORAGE	11
6. CE DECLARATION OF CONFORMITY	14
7. WARRANTY	15
8. PRODUCT FAILURE	16
9. WARRANTY EXCLUSIONS	17

1. SAFETY INSTRUCTIONS

IMPORTANT

Read carefully before use

Keep for future reference

Safe operating practices

1.1 Training

Become familiar with the instructions before attempting to operate the equipment.

1.2 Preparation

a) THIS HEDGE TRIMMER CAN CAUSE SERIOUS INJURIES. Read the instructions carefully for the correct handling, preparation, maintenance, starting and stopping of the hedge trimmer. Become familiar with all controls and the proper use of the hedge trimmer.

b) Never allow children to use the hedge trimmer.

c) Beware of overhead power lines.

d) Avoid operating while people, especially children, are nearby.

e) Dress properly! Do not wear loose clothing or jewellery, which can be caught in moving parts. Use of sturdy gloves, non-skid footwear and safety glasses is recommended.

f) Use extra care when handling fuels. Fuel is flammable and the vapours are explosive. The following points should be observed.

1) Use only an approved container.

2) Never remove the fuel cap or add fuel with the power source running. Allow engine and exhaust components to cool down before refuelling.

3) Do not smoke.

4) Never refuel indoors.

5) Never store the hedge trimmer or fuel container inside where there is an open flame, such as near a water heater.

6) If fuel is spilled, do not attempt to start the power source, but move the hedge trimmer away from the spillage before starting.

7) Always replace and securely tighten the fuel cap after refuelling.

8) If the fuel tank is drained, this should be done outdoors.

g) If the cutting mechanism strikes any foreign object or the hedge trimmer starts making any unusual noise or vibration, shut off the power source and allow the hedge trimmer to stop. Disconnect the spark plug wire from the spark plug and take the following steps.

1) Inspect for damage.

2) Check for, and tighten, any loose parts.

3) Have any damaged parts replaced or repaired with parts having equivalent specifications.

h) Warn of the need for ear protection.

i) Warn of the need for eye protection.

j) Instruct in how to stop the hedge trimmer in an emergency.

1.3 Operation

This product is only intended to hedge trimmer and it should not be used for any other purpose.

a) Stop the engine before:

1) cleaning or when clearing a blockage;

2) checking, carrying out maintenance or working on the hedge trimmer;

3) adjusting the working position of the cutting device;

4) leaving the hedge trimmer unattended.

- b) Ensure that the hedge trimmer is correctly located in a designated working position before starting the engine.
- c) While operating the hedge trimmer, always ensure that the operating position is safe and secure, especially when using steps or a ladder.
- d) Do not operate the hedge trimmer with a damaged or excessively worn cutting device.
- e) To reduce fire hazards, keep the engine and silencer free of debris, leaves and excessive lubricant.
- f) Always ensure that all handles and guards are fitted when using the hedge trimmer. Never attempt to use an incomplete hedge trimmer or one fitted with an unauthorized modification.
- g) Always use two hands to operate a hedge trimmer.
- h) Always be aware of your surroundings and stay alert for possible hazards of which you might not be aware due to the noise of the hedge trimmer.

1.4 Maintenance and storage

- a) When the hedge trimmer is stopped for servicing, inspection or storage, shut off the power source, make sure all moving parts have come to a stop and disconnect the spark plug wire from the spark plug. Allow the hedge trimmer to cool before making any inspections, adjustments, etc.
- b) Store the hedge trimmer where the fuel vapour will not reach an open flame or spark. Always allow the hedge trimmer to cool down before storing.
- c) When transporting or storing the hedge trimmer, always fit the cutting device transport guard.



- Never use hedge trimmer inside a building. Your hedge trimmer produces toxic exhaust fumes as soon as the engine is started. The use of this product can generate dust, vapours and smoke containing chemicals known for their harmful effects on health. So be careful during the use of your machine and protect yourself correctly. Also avoid voluntarily breathing exhaust fumes; always hold the machine correctly when you use it.
- Wear adapted protective clothing, because remains can be projected by the machine. Use a working clothes adjusted well with the body and without floating parts as well as protection for the head for the people having long hair which could be caught in the moving parts of the device.

Explanation of the symbols



Security standards



Read the instruction manual before use



Do not expose to rain.



This CE sticker attests conformity with the European standards of safety.



Use anti skidding shoes of work and be maintained quite assured on its two legs. Wear protective gloves for any intervention on the blade.



Wear ear protection



Wear head protection.



Wear eyes protection.



Do not approach the hands of the blades during operation.



Wear protective clothing

Residual risks

Even if you use this product in compliance with all safety requirements, the potential risks of injury and damage remain. The following hazards may arise in the structure and design of this product. Always be vigilant when using this product, so you can recognize and manage the risks rather. Rapid intervention can prevent serious injury and property damage.

- There are harmful health consequences resulting from the emission of vibrations if the product is used for long periods of time or not properly managed and properly maintained.
- There is risk of injury and property damage due to attachments or broken the sudden impact of hidden objects.
- Risk of injury to persons and property caused by flying objects.
- Prolonged use of this product exposes the operator to vibration and can produce so-called "white finger" disease. To reduce the risk, wear gloves and keep your hands warm. If any of the symptoms of "white finger syndrome" occur, seek immediate medical attention. Symptoms of the "white finger" include numbness, loss of sensitivity, tingling, tingling, and pain, loss of strength, color changes or skin condition. These symptoms usually appear on the fingers, hands or wrists. Risk increases at low temperatures
- Inhalation of particles
- Inhalation of exhaust gases
- Unattended projections
- Contact with foreign objects
- Contact with the tool in operation
- Hearing loss in the absence of correct hearing protection

Intended use

This product is only intended to hedge trimmer.

- The use of accessories other than those provided by the manufacturer can appear dangerous.
- Any use different from that recommended or any modification of the device increases the accident risks considerably. The manufacturer declines any responsibility in the event of incidents resulting from a use different from that recommended or in the event of modification of the device.
- This device was not designed for a professional use.

2. YOUR PRODUCT

a. Description

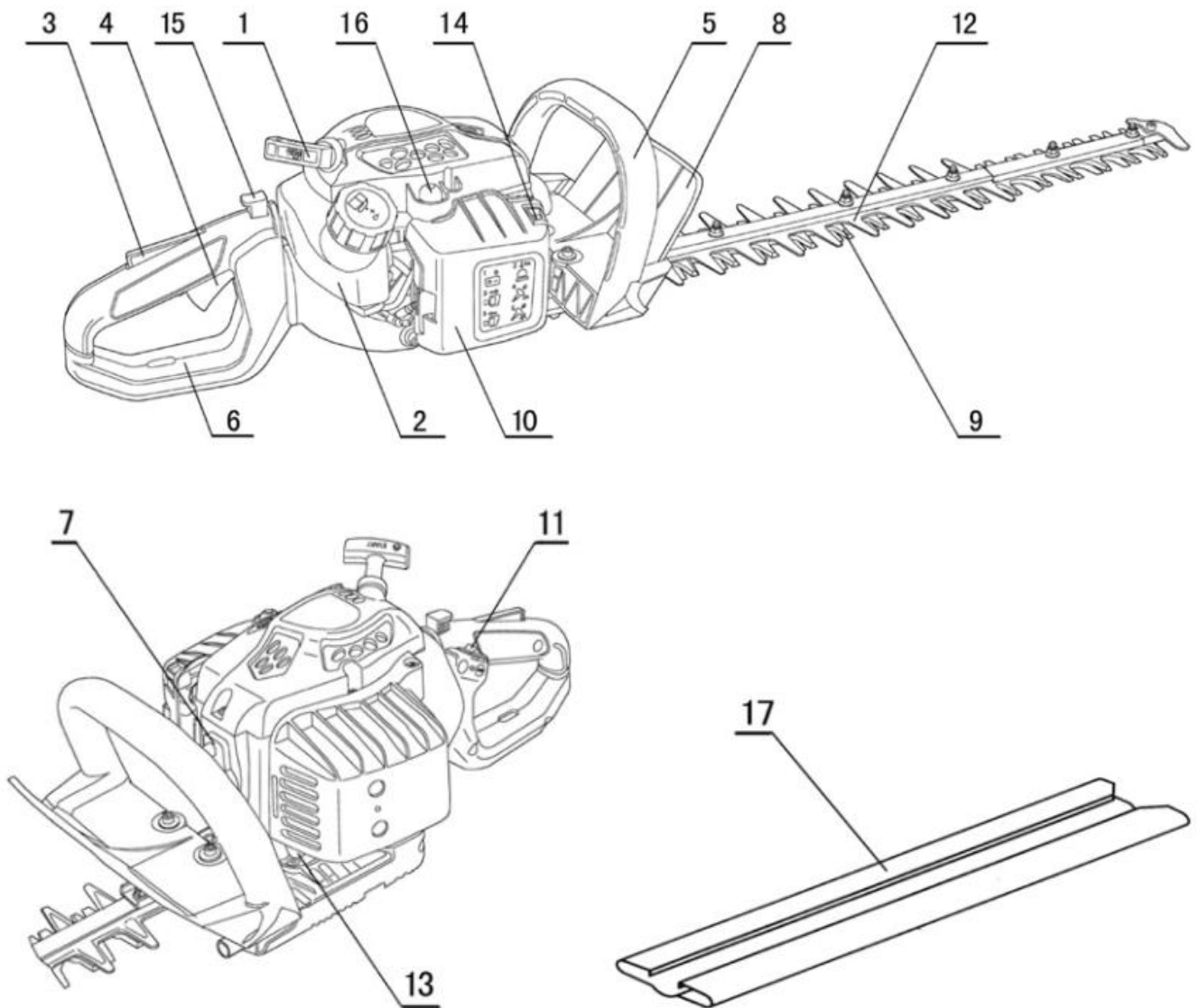

- | | | | |
|---------------------------|------------------|-----------------|------------------|
| 1. Recoil starter | 6. Rear handle | 11. Stop switch | 16. Priming pump |
| 2. Fuel tank | 7. Spark plug | 12. Blade guide | 17. Blade case |
| 3. Throttle lever lockout | 8. Hand guard | 13. Gear case | 18. Tool bag |
| 4. Throttle lever | 9. Cutting blade | 14. Choke lever | |
| 5. Front handle | 10. Air cleaner | 15. Lock lever | |

b. Technical data

Displacement	21,7cm ³
Max engine speed	11000min ⁻¹
Max engine power	0,65kW/8000min ⁻¹
Synthetic oil / gasoline.	2,5% (1:40)
Type of gasoline for mixture	Unleaded 95 RON
Fuel tank capacity	230ml
Cutting length	550mm
Width teeth	28mm
Weight	4,8 kg
Sound pressure level	L _{pA} =85,5dB(A) K = 3 dB(A)
Sound power level	L _{wA} =99,5dB(A) K = 3,0dB(A)
Level of sound power guaranteed	L _{wA} : 103dB(A)
Handlebar level of vibration	Rear handle 7,672 m/s ² (K = 1,5 m/s ²) Front handle 5,348 m/s ² (K = 1,5 m/s ²)

3. FILLING WITH FUEL

a. Basics precaution

- Always use extreme care when handling fuel! Fuel is highly flammable.
- Do not fill the tool with fuel if the fuel system components are damaged or are leaking.
- Never attempt the refuel the engine while it is running or still warm, allow it to cool before fuelling.
- Never smoke or light any fires near the tool or fuels.
- Always transport and store fuels in an approved container.
- Do not use petrol which contains ethanol or methanol as it may damage the fuel lines and other parts.
- Mix only enough fuel for your immediate needs.
- Never use a mixture oldest than 30 days.

b. Mixture (Fig.1)

Carry out the mixture with **unleaded 95 RON** added **with special 2 strokes synthetic oil in the proportion of 2.5%** (1:40).

Example:

- For 1 L gasoline to add 25ml synthetic oil
- 2 L gasoline to add 50ml synthetic oil
- 3L gasoline to add 75ml synthetic oil ... etc.

Vigorously mix the fuel and oil in the provided vessel. Do not mix directly in the fuel tank of the tool.

Caution: Do not use a percentage different from that recommended by the manufacturer and never use pure gasoline.

c. **Filling (Fig.2)**

- Unscrew the fuel cap of the fuel tank and put the mixture using a funnel (take care not to wear synthetic clothing at the time of this operation in order not to risk an electric arc being able to cause a dangerous explosion.).
- Wipe the tank and the engine of any possible gasoline traces.
- Close the fuel tank with its cap.

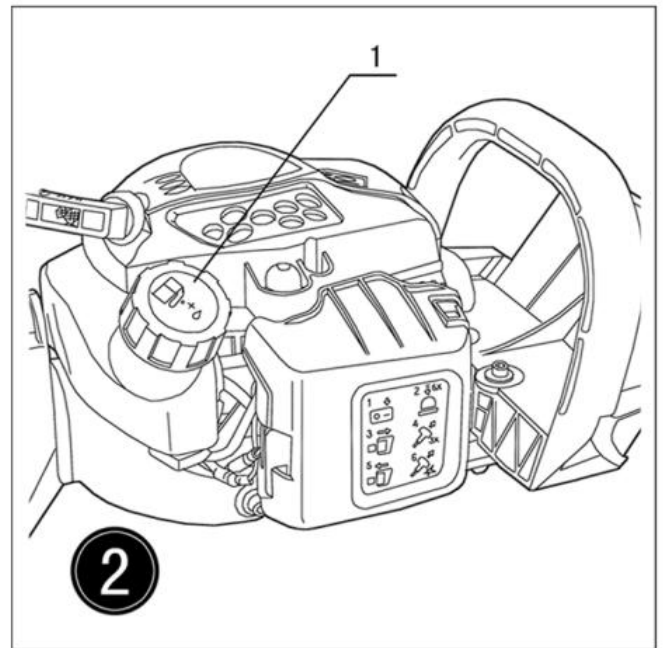
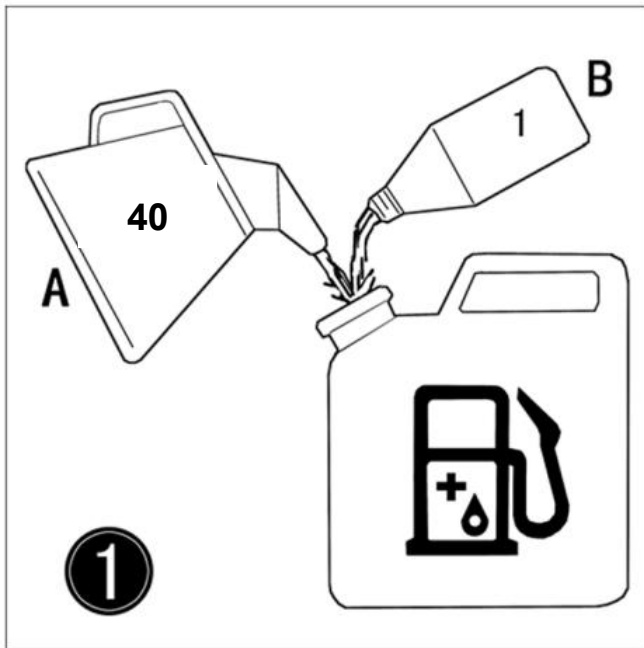

4. OPERATION

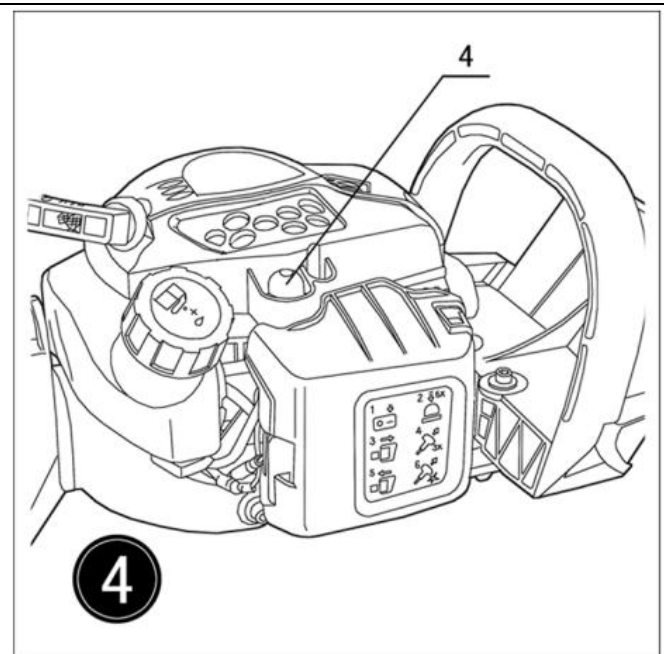
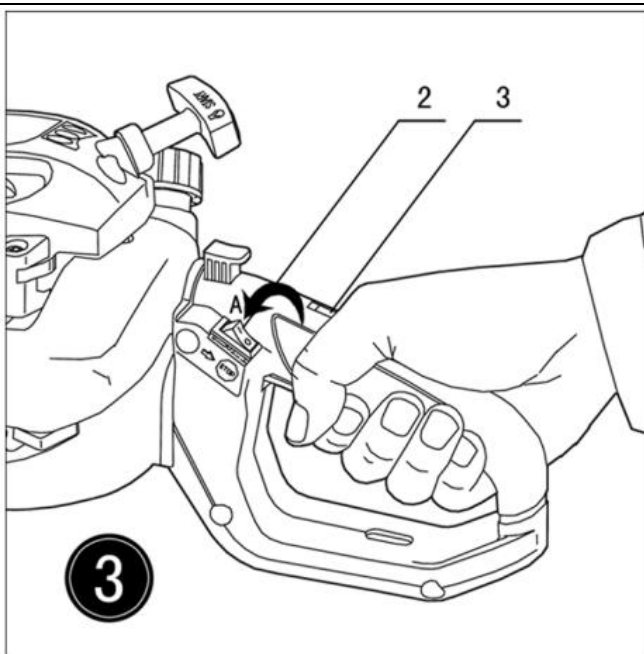

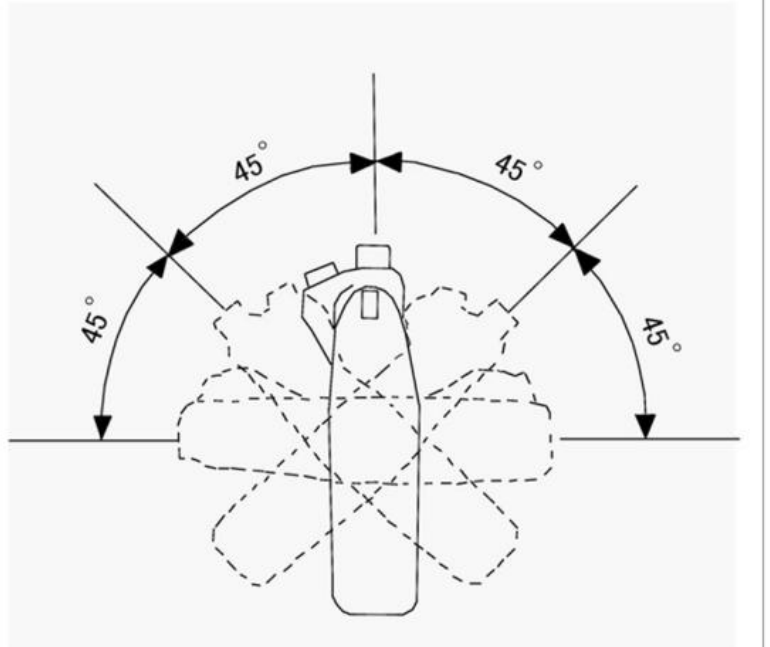
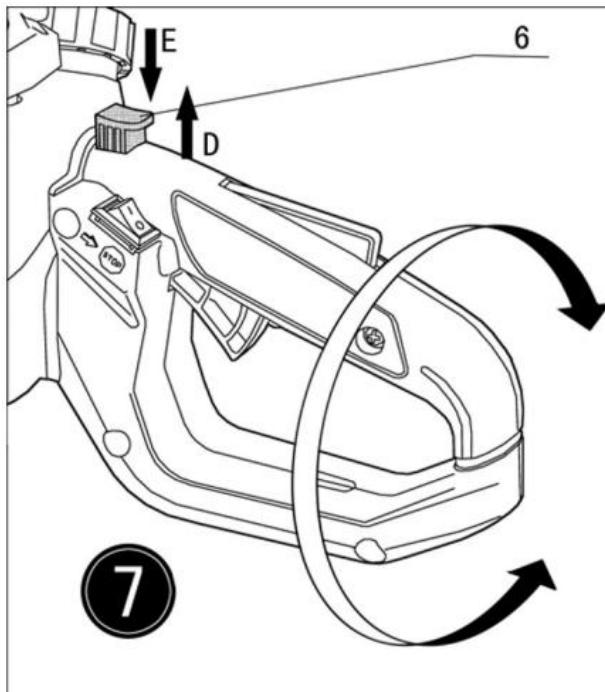
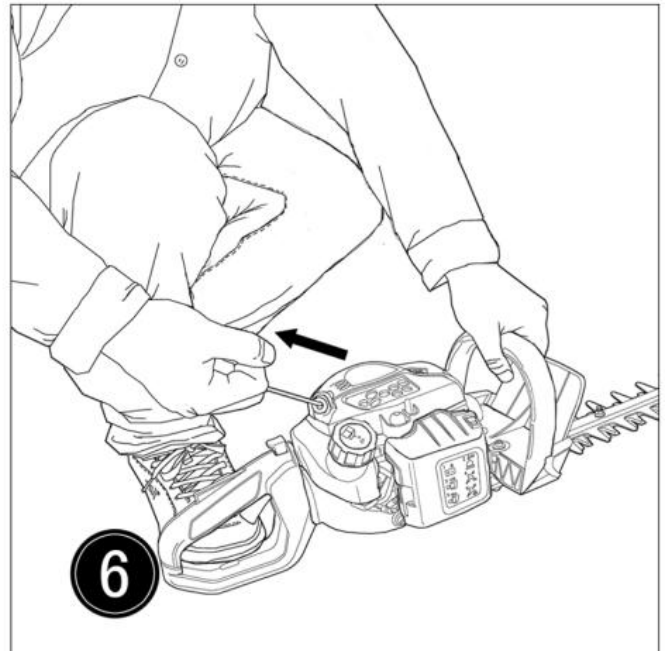
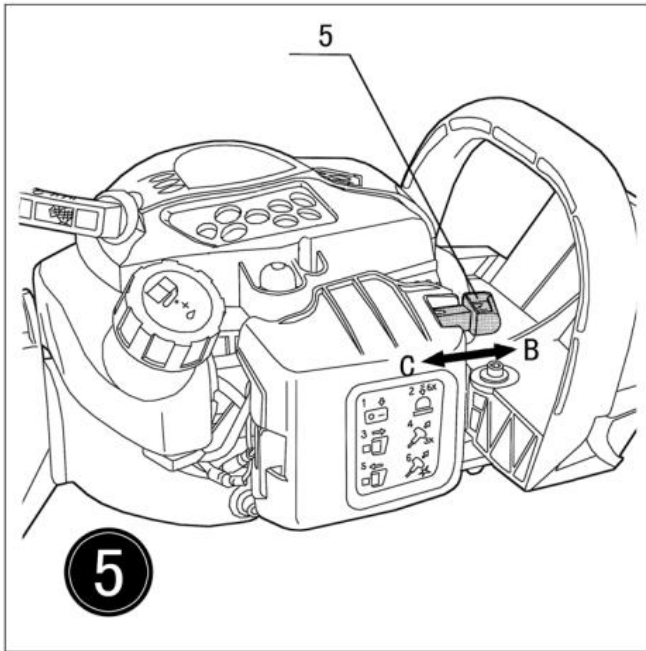

Use this device only when you are absolutely sure to control all the functions of it well. In case of doubts, read again this handbook or inform yourself near a qualified person and/or your retailer. Ensure to be able to easily turn off the engine with the STOP button of the handle.

a. Before cutting

- Make sure that the tool is properly assembled.
- Inspect the work area. Remove any materials or objects that may damage the tool or cause accidents.
- Remember that you must wear full protective gear and keep spectators away from the work area.
- Be careful to have a good walk and balance. Hold the tool with both hands firmly and keep it at an ideal distance from your body.

b. Starting

CAUTION: Before starting, make sure the cutting attachment does not touch anything.

- Set stop switch (2) to ON position (A). (Fig.3) Push priming pump(4) several times so that fuel flows through the pump or return pipe.(Fig.4)
- Set choke lever(5) to CLOSED position(B).(Fig.5)

- Pull recoil starter briskly, taking care to keep the handle in your grasp and not allowing it to snap back.(Fig.6)
- When you hear the engine attempts to start, return choke lever to RUN position (open) (C) Then pull recoil starter briskly again.

NOTE: If engine does not start procedures from 2 to 4.5. After starting engine, slow the engine about 2-3 minutes to warm up before subjecting it to any load.

c. Cutting techniques

- Position a hand on the rear handle so as to press on the lever of safety and the other hand on the front handle. Accelerate the engine while pressing on the accelerator lever of the handle.
- Maintain an engine speed in order to profit of the best power of cut available.
- Immediately stop the engine with the STOP button if you run up against either a stone or a too large branch. Control the state of the blade after any similar incident. Do not put back on the way in case of doubt.
- Always be vigilant and well ensured on your two legs when you are using the hedge trimmer and more especially on difficult grounds, sloping or are positioned on a scale.
- It is recommended to cut the trapezoidal hedges to prevent the lower branches from being stripped. This corresponds to the natural growth of plants and hedges can be potentially prosperous. The cut makes the new annual shoots reduced, so a dense branching and a good protection of the sight must be considered.
- First cut the edges of a hedge. Move the hedge trimmer to cut the part that grows greatly from bottom to top. If you cut from top to bottom, the thinner branches move outward; Narrow places or holes may form.
- Cut the top of the hedge, just like a roof or a round shape.
- Cut the seedlings into the desired shape. The main stem must be intact and remain until the hedge reaches the proposed elevation. All other shoots should be cut to half.

NOTE

- Multi-position twist handle (Fig.7) The rear control handle turns 90 degrees to provide comfortable use while accommodating a variety of cutting angles. The handle allows for five different locking positions. Before attempting to adjust rear handle, make sure the machine is at idle or engine is shut off.
- The throttle lever cannot be engaged if the handle is not secured (the lock lever is pressed).To rotate the handle, push the lock lever (6) allowing the handle to turn. Rotate the handle to the desired 0° , 45° or 90° locking position and release the lock lever (6) to lock the handle in place.
- D: LOCK
- E: UNLOCK

d. Engine stopping(Fig.8)

Decrease engine speed and push stop switch to stop position (F)

NOTE

- If the engine does not stop, it can be forced to stop by rotating the choke lever to the choked position.
- Before restarting the engine, ask Authorized Service Centers for repairs.

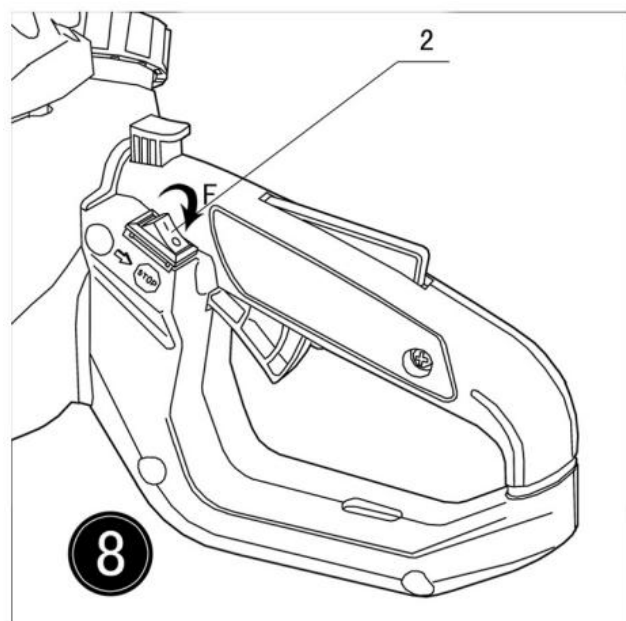

5. MAINTENANCE AND STORAGE

Before any maintenance operation on the material turn off the engine with the STOP button and withdraw the spark plug cap.

When cleaning, do not use detergents, solvents or objects being able to stripe.

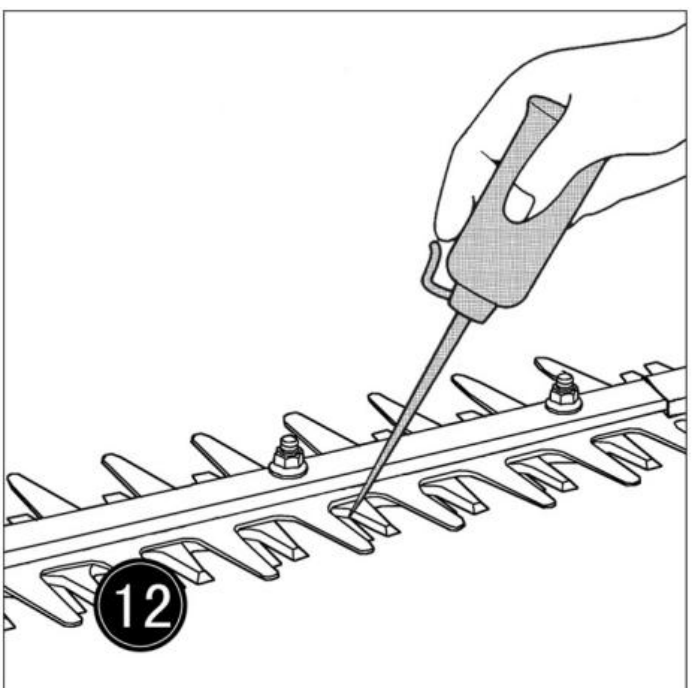
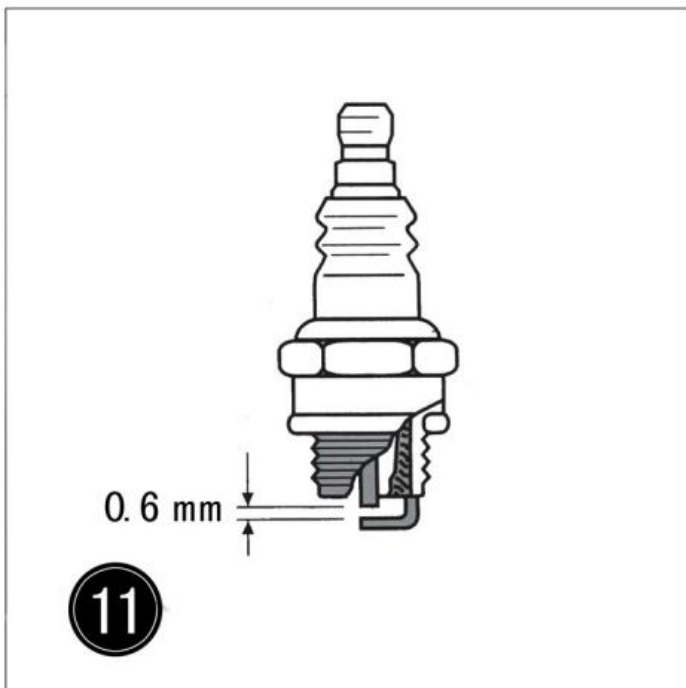
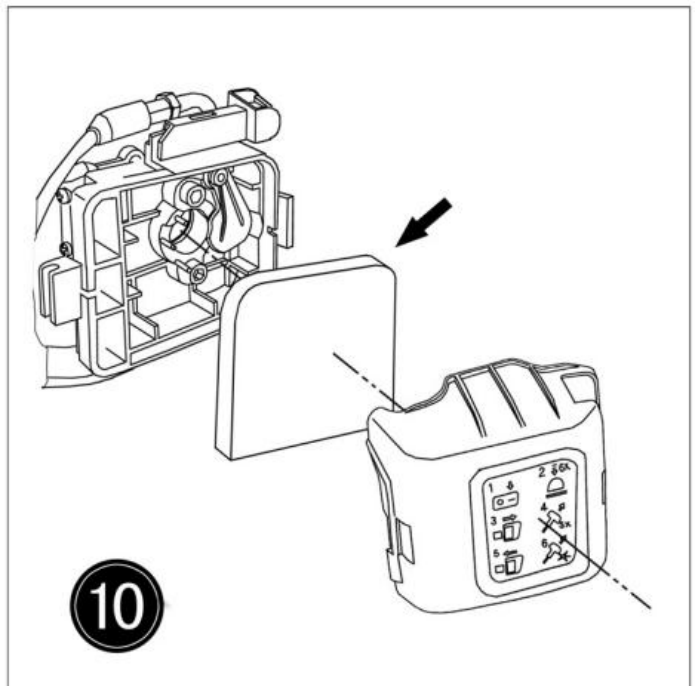
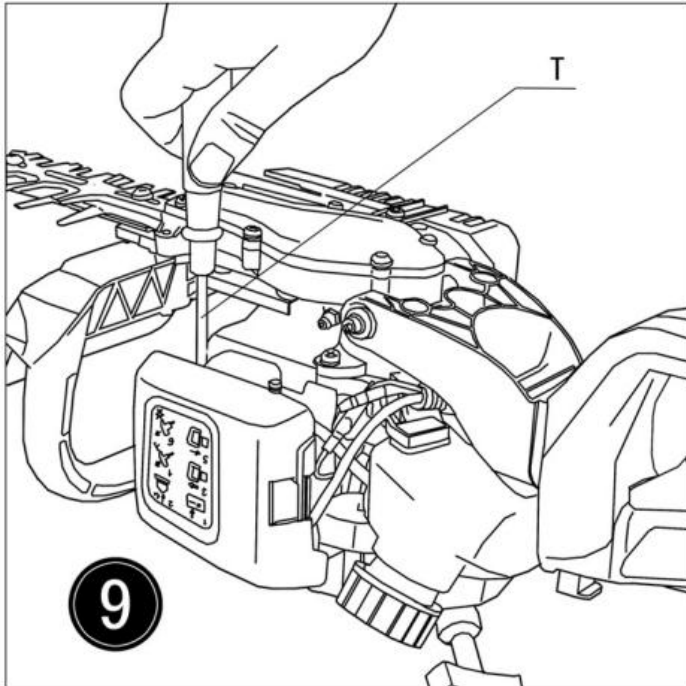

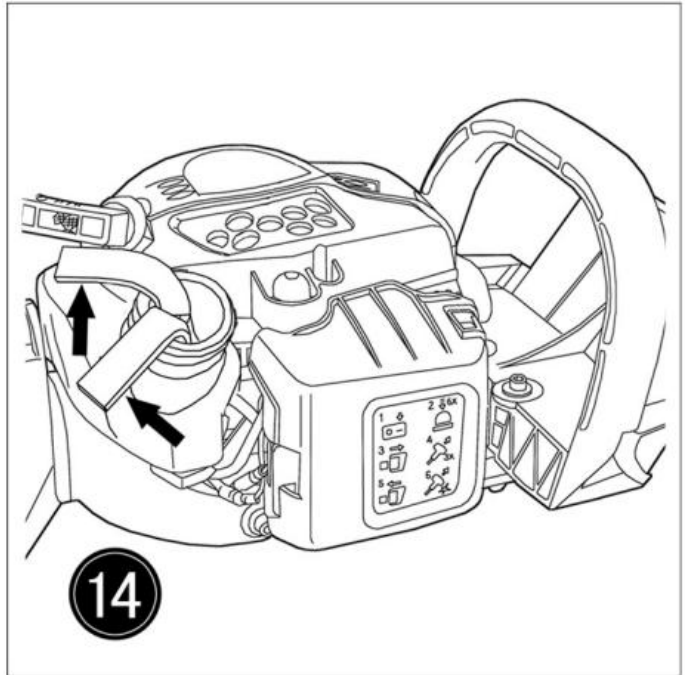
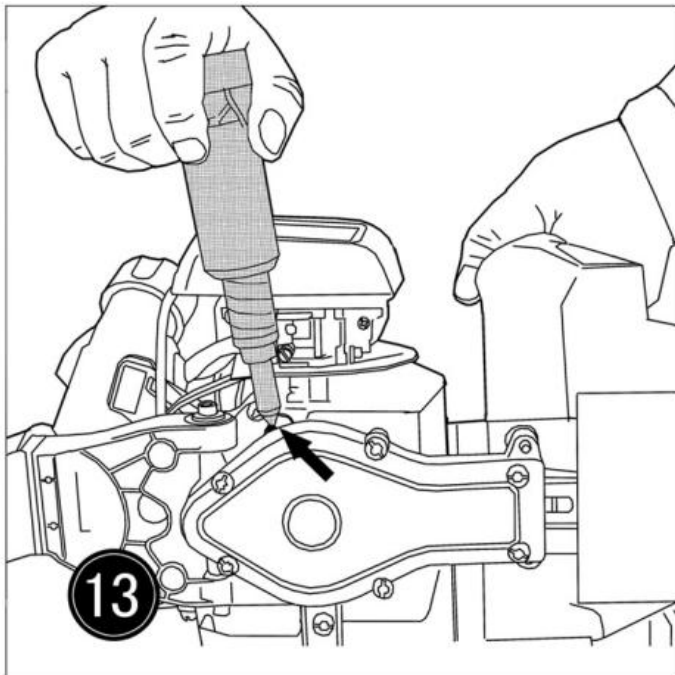

a. After each use

- Clean the body of the tool by using a soft cloth.
- Clean all the air intake and moving parts with a brush. Use protective gloves during this operation.
- Check all parts of the tool (cleanliness, wear, damage, etc.). If you notice damage, wear, or malfunction, do not use the tool and bring it to a qualified service for inspection and repair.
- Regularly oil the blade. Use only biodegradable oils.

b. Adjustment of the carburetor(Fig.9)

WARNING!

- The cutting attachment may be spinning during carburetor adjustments.
- Never start the engine without the complete cleaner cover. Otherwise the clutch can come loose and cause personal injuries.
- In the carburetor, fuel is mixed with air. When the engine is test run at the factory, the carburetor is adjusted. A further adjustment may be required, according to climate and altitude. The carburetor has one adjustment possibility: T=Idle speed adjustment screw.
- Idle speed adjustment(T)

Check that the air filter is clean when the idle speed is correct, the cutting attachment will not rotate. If adjustment is required ,close(clockwise) the T-screw, with the engine running, until the cutting attachment starts to rotate. Open (counter-clockwise) the screw until the cutting attachment stops, You have reached the correct idle speed when the engine runs smoothly in all positions, well below the rpm when the cutting attachment starts to rotate. If the cutting attachment still rotates after idle speed adjustment, contact dealer.

c. Air filter(Fig.10)

The air filter must be cleaned from dust and dirt in order to avoid:

- Carburetor malfunctions.
- Starting problems.
- Engine power reduction.
- Unnecessary wear on the engine parts.
- Abnormal fuel consumption.
- Clean the air filter daily or more often if working in exceptionally dusty areas.

Cleaning the air filter

Remove the cleaner cover and the filter. Rinse it in warm soap suds. Check that the filter is dry before reassembly. An air filter that has been used for some time cannot be cleaned completely. Therefore, it must regularly be replaced by a new one. A damaged filter must always be replaced.

NOTE

Saturate the element in 2-cycle oil or the equivalent. Squeeze the element to distribute the oil completely and to remove any excess oil.

d. Spark plug (Fig.11)

The spark plug condition is influenced by:

- An incorrect carburetor setting.
- Wrong fuel mixture (too much oil in the gasoline).
- A dirty air filter.
- Hard running conditions (such as cold weather)

These factors cause deposits on the spark plug electrodes, which may result in malfunction and starting difficulties. If the engine is low on power, difficult to start or runs poorly at idling speed, always check the spark plug first. If the spark plug is dirty, clean it and check the electrode gap. Readjust if necessary. The correct gap is 0.6 mm. The spark plug should be replaced after about 100 operation hours or earlier if the electrodes are badly eroded.

NOTE

In some areas, local law requires using a resistor spark plug to suppress ignition signals. This machine was originally equipped with resistor spark plug, use the same type of spark plug for replacement.

e. Lubricating the blade (Fig.12)

During trimming, sap adhering to the blade edge will increase load. Use machine oil (or bicycle oil or the like) to lubricate the blade and wipe the blade with a cloth. To prevent the blade from rusting, be sure to lubricate the blade after use and when it will not be used for an extended period of time before placing it in the blade case.

f. Gear case (Fig.13)

Apply a good quality lithium based grease through the grease fitting until a small amount comes out between the cutting blades and the gear case. Lubricate the grease from the grease nipple (indicated by an arrow) next to the gear case using a commercially available cartridge grease gun.

g. Fuel filter (Fig.14)

Remove the fuel filter from the fuel tank and thoroughly wash it in solvent. After that, push the filter into the tank completely.

h. Storage

- Empty the tank completely as soon as the mixture is oldest than thirty days or make function the engine until exhaustion of the fuel.
- In this second case empty the gasoline residues located at the bottom of the tank.
- Let cool the engine and dismount the spark plug.
- Store the hedge trimmer in a dry place.
- Put the blade cover on the blade when transport and storage in order avoid accidents and injuries.
- The tool must be stored out of the reach of children.

6. CE DECLARATION OF CONFORMITY



32, rue Aristide Bergès - ZI 31270 Cugnaux - France, déclare que,
Product: **Gasoline Hedge Trimmer**

Model: FHT22

Serial number: 20230603485-20230603784

Is in conformity with the essential requirements and other relevant provisions of the applicable European Directives, based on the application of European harmonized standards. Any unauthorized modification of the apparatus voids this declaration.

European Directives
Directive Machine 2006/42/EC
Directive EMC 2014/30/EU
EMISSION Directive 2016/1628/EU & 2017/656/EU
EU Type-Approval number: e9*2016/1628*2016/1628SHA1/P*1142*00
European harmonized standards
EN ISO 10517: 2019
EN ISO 14982: 2009

Cugnaux, 26/05/2023



Philippe MARIE / PDG

Responsible of the technical file: M. Olivier Patriarca

This declaration of conformity is issued under the sole responsibility of the manufacturer.

7. WARRANTY



WARRANTY

The manufacturer guarantees the product against defects in material and workmanship for a period of 2 years from the date of the original purchase. The warranty only applies if the product is for household use. The warranty does not cover breakdowns due to normal wear and tear.

The manufacturer agrees to replace parts identified as defective by the designated distributor. The manufacturer does not accept responsibility for the replacement of the machine, in whole or in part, and/or ensuing damage.

The warranty does not cover breakdowns due to:

- insufficient maintenance.
- abnormal assembly, adjustment or operations of the product.
- parts subject to normal wear and tear.

The warranty does not extend to:

- shipping and packaging costs.
- using the tool for a purpose other than that for which it was designed.
- the use and maintenance of the machine done in a manner not described in the user manual.

Due to our policy of continuous product improvement, we reserve the right to alter or change specifications without notice. Consequently, the product may be different from the information contained therein, but a modification will be undertaken without notice if it is recognized as an improvement of the preceding characteristic.

READ THE MANUAL CAREFULLY BEFORE USING THE MACHINE.

When ordering spare parts, please indicate the part number or code, you can find this in the spare parts list in this manual. Keep the purchase receipt; without it, the warranty is invalid. To help you with your product, we invite you to contact us by phone or via our website:

- **+33 (0)9.70.75.30.30**
- **<https://services.swap-europe.com/contact>**

You must create a "ticket" via the web platform.

- Register or create your account.
- Indicate the reference of the tool.
- Choose the subject of your request.
- Describe your problem.
- Attach these files: invoice or sales receipt, photo of the identification plate (serial number), photo of the part you need (for example: pins on the transformer plug which are broken).



8. PRODUCT FAILURE

WHAT TO DO IF MY MACHINE BREAKS DOWN?

If you bought your product in a store:

- a) Empty the fuel tank if your product has one.
- b) Make sure that your machine is complete with all accessories supplied, and clean! If this is not the case, the repairer will refuse the machine.

Go to the store with the complete machine and with the receipt or invoice.

If you bought your product on a website:

- a) Empty the fuel tank if your product has one.
- b) Make sure that your machine is complete with all accessories supplied, and clean! If this is not the case, the repairer will refuse the machine.
- c) Create a SWAP-Europe service ticket on the site: <https://services.swap-europe.com> When making the request on SWAP-Europe, you must attach the invoice and the photo of the nameplate (serial number).
- d) Contact the repair station to make sure it is available before dropping of the machine.

Go to the repair station with the complete machine packed, accompanied by the purchase invoice and the station support sheet downloadable after the service request is completed on the SWAP-Europe site

For machines with engine failure from manufacturers BRIGGS & STRATTON, HONDA and RATO, please refer to the following instructions.

Repairs will be done by approved engine manufacturers of these manufacturers, see their site:

- <http://www.briggsandstratton.com/eu/fr>
- <http://www.honda-engines-eu.com/fr/service-network-page;jsessionid=5EE8456CF39CD572AA2AEEDFD290CDAE>
- <https://www.rato-europe.com/it/service-network>

Please keep your original packaging to allow for after-sales service returns or pack your machine with a similar cardboard box of the same dimensions.

For any question concerning our after-sales service you can make a request on our website <https://services.swap-europe.com>

Our hotline remains available at +33 (9) 70 75 30 30.



9. WARRANTY EXCLUSIONS

THE WARRANTY DOES NOT COVER:

- Start-up and setting up of the product.
- Damage resulting from normal wear and tear of the product.
- Damage resulting from improper use of the product.
- Damage resulting from assembly or start-up not in accordance with the user manual.
- Breakdowns related to carburetion beyond 90 days and fouling of carburetors.
- Periodic and standard maintenance events.
- Actions of modification and dismantling that directly void the warranty.
- Products whose original authentication marking (brand, serial number) has been degraded, altered or withdrawn.
- Replacement of consumables.
- The use of non-original parts.
- Breakage of parts following impacts or projections.
- Accessories breakdowns.
- Defects and their consequences linked to any external cause.
- Loss of components and loss due to insufficient screwing.
- Cutting components and any damage related to the loosening of parts.
- Overload or overheating.
- Poor power supply quality: faulty voltage, voltage error, etc.
- Damages resulting from the deprivation of enjoyment of the product during the time necessary for repairs and more generally the costs related to the immobilization of the product.
- The costs of a second opinion established by a third party following an estimate by a SWAP-Europe repair station
- The use of a product which would show a defect or a breakage which was not the subject of an immediate report and/or repair with the services of SWAP-Europe.
- Deterioration linked to transport and storage*.
- Launchers beyond 90 days.
- Oil, petrol, grease.
- Damages related to the use of non-compliant fuels or lubricants.

* In accordance with transport legislation, damage related to transport must be declared to carriers within 48 hours maximum after observation by registered letter with acknowledgement of receipt.

This document is a supplement to your notice, a non-exhaustive list.

Attention: all orders must be checked in the presence of the delivery person. In case of refusal by the delivery person, it you must simply refuse the delivery and notify your refusal.

Reminder: the reserves do not exclude the notification by registered letter with acknowledgement within 72 hours.

Information:

Thermal devices must be wintered each season (service available on the SWAP-Europe site). Batteries must be charged before being stored.

FEIDER

MACHINES



BUILDER SAS
32, rue Aristide Bergès - ZI 31270 Cugnaux – France
Made in China in 2023